

De Santis

**INCOLLACARTONI
AUTOMATICO
VELOCE AM/85**

**CASE
GLUER-SEALER
AM/85 MODEL**

**ENCOLLEUSE
À GRAND
RENDEMENT
AM/85**

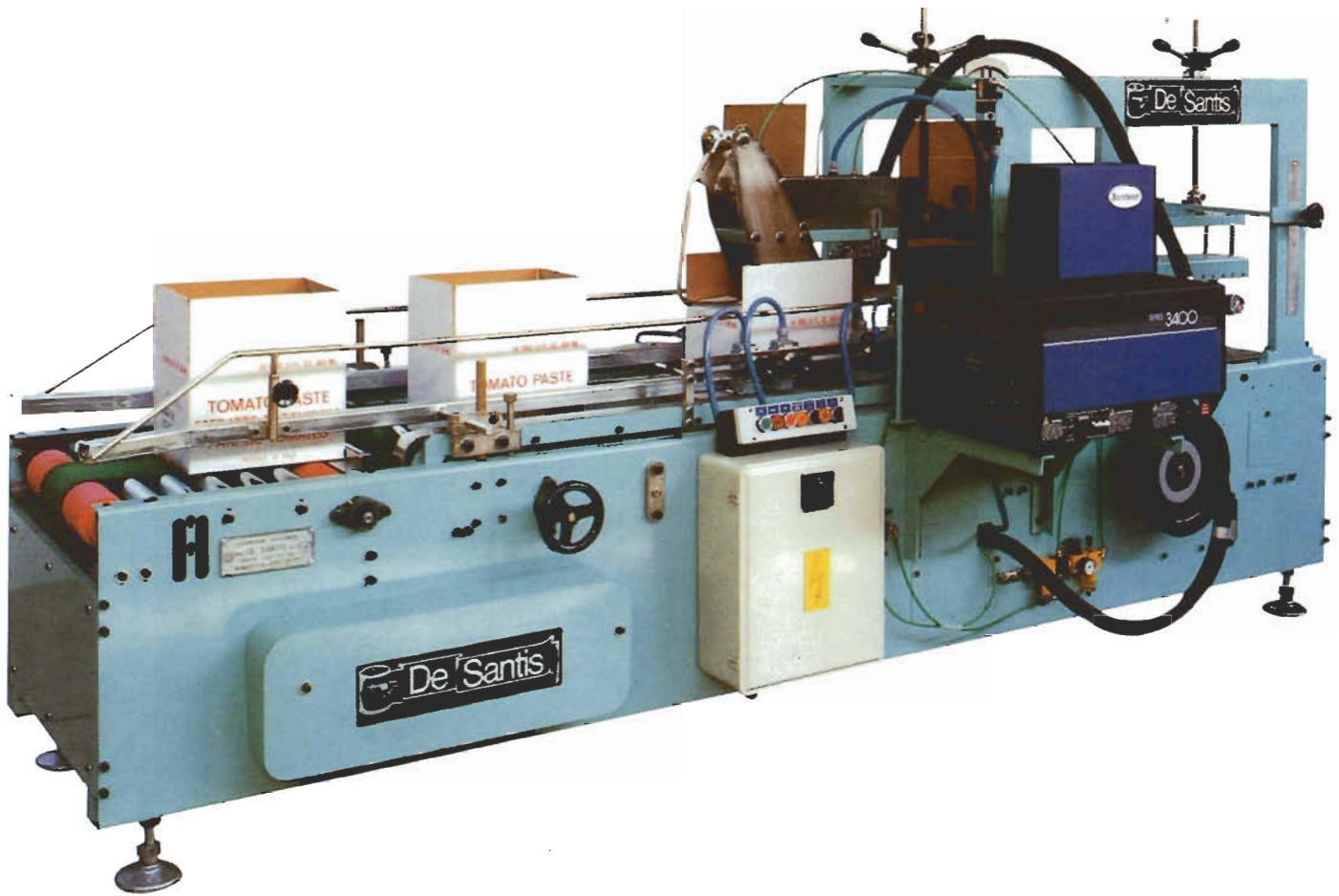

CARATTERISTICHE GENERALI

Modelli: AM 85 - AM 95

Uso: per incollare automaticamente le patte superiori ed inferiori dei cartoni, insieme o separatamente.

Funzionamento: I cartoni vengono immessi nella macchina con le patte inferiori piegate e quelle superiori aperte in posizione corretta. La macchina provvede a distanziare i cartoni, ad aprire le falde inferiori ad applicare la colla su quelle inferiori e su quelle superiori, ed a comprimere il cartone dopo l'incolatura. Il gruppo di compressione è compreso nella fornitura.

Colla: L'applicazione della colla è effettuata a fusione «hot melt» per mezzo di apparecchio originale speciale.

Funzionamento sicuro ed efficace.

Velocità: fino a 30 cartoni/minuto secondo i formati.

Formati: macchina regolabile per tutti i formati conservieri, dal cartone di 50 barattoli da 70 gr. fino al cartone da 5 Kg. V. sotto. Il cambio del formato è semplicissimo e richiede da 5 a 20 minuti al massimo.

Potenza: Trifase: richiesta 0,5 KW massima - Monofase: richiesta 3 KW massima.

Aria compressa: massima 0,100 mc/min a 4,3 bar.

CARACTERISTIQUES GENERALES

Modèles: AM 85 - AM 95

Utilization: Fermeture et encollage des rabats inférieurs et/ou supérieurs par «hot-melts»; pressage finale des caisses.

Fonctionnement: Les caisses en carton précablement remplies, sont à emmener avec les rabats inférieurs pliés et les rabats supérieurs en position correcte.

Un poste de sélection-distribution écarte les caisses; ensuite les petits rabats supérieurs sont fermés automatiquement; au cours de leur cheminement, les rabats inférieurs sont ouverts, la colle «hot-melt» (colle chaude) est appliquée à leurs deux extrémités, puis fermés et pressés (poste de pressage inclusif).

Colle: La colle chaude «hot-melt» est appliquée par un dispositif automatique.

Cadence: Jusq'à 30 caisses/minute suivant formats.

Formats admis: Toutes caisses utilisées en conserveries.

Dimensions max e mini admis: voir croquis ci-dessous.

Changement de formats: Très simple et rapide en 10 minutes maxi.

Puissance électrique: moteur triphase, totale 0,5 KW; appareil, monophasé 3 kW.

Air comprimé: 140 l/min. à 4,5 bar.

Poids: poids net Kg. 800 - poids brut (en cage) Kg. 1050 - poids brut (en caisse) Kg. 1200.

GENERAL INFORMATION

Machine Type: AM 85 - AM 95 vertical case gluer and sealer.

Application: for gluing and sealing cartons for food-industry.

Method of operation: This unit is suitable for the application of glue on the top and or the bottom flaps of cartons in vertical position. The application of the glue is obtained by means of the special «Hot Melt Applicator». The unit may glue separately or simultaneously the top and the bottom flap of the carton.

Motorized compression device including belt and rolls is included in the normal standard supply.

Immediate connection is obtained with our «Case Packer» of the «PN» and «PNM» serial, but operating height of the unit, which is adjustable, is generally compatible with other packaging units.

Operating speed: up to 30 cases/minute according to the size.

Size range: see below.

Champing the size: minimum 5 minutes, maximum 10 minutes according to the size of the carton.

Power: 3phases motor, total 0,5 kW. - Hot melt applicator 3 kW (220/50 1phase).

Air requirements: 0,140 mc/min. at 10 c.p.m., at 4,3 bar.

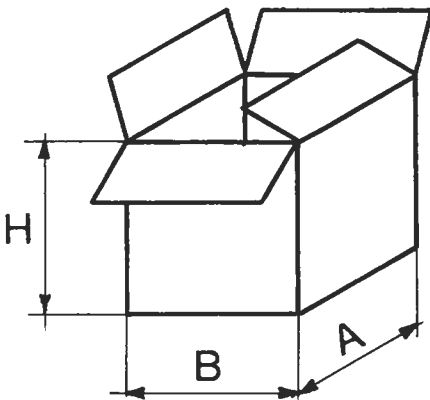

MODELLO TYPE MODEL	A (mm.) MIN-MAX	B (mm.) MIN-MAX	H (mm.) MIN-MAX	L (mm.)	PESO POIDS WEIGTS
AM 85	200-480	150-400	75-450	3200	900 Kg.
AM 95	200-650	150-430	75-450	4600	1200 Kg.

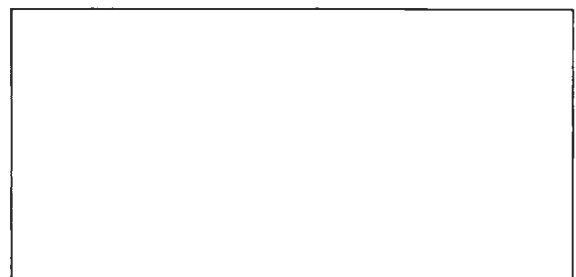
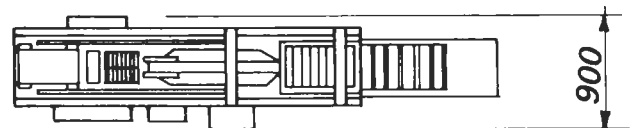
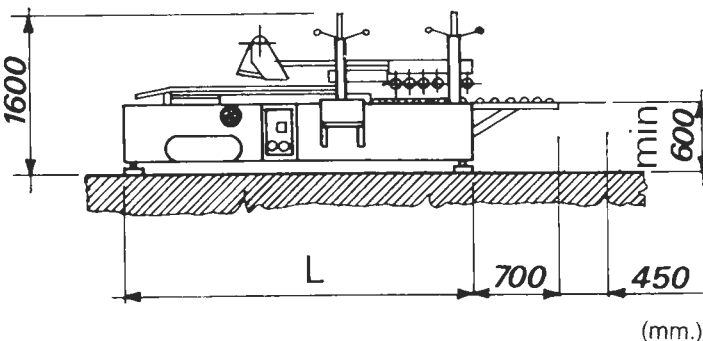

De Santis s.r.l. - PACKAGING MACHINERY AND EQUIPMENT

Via De Gasperi, 96 - I - 84016 Pagani (SA) - Italia - Tel. (+39 081) 915344 - Telefax (+39 081) 5152066

E-mail: info@de-santis.biz